

TACK UPPER SECTION AFTER  
CLAMPED INTO POSITION

CENTER TABS IN SLOTS  
(USE 90° MAGNETS)

TACK LOWER SECTION FIRST

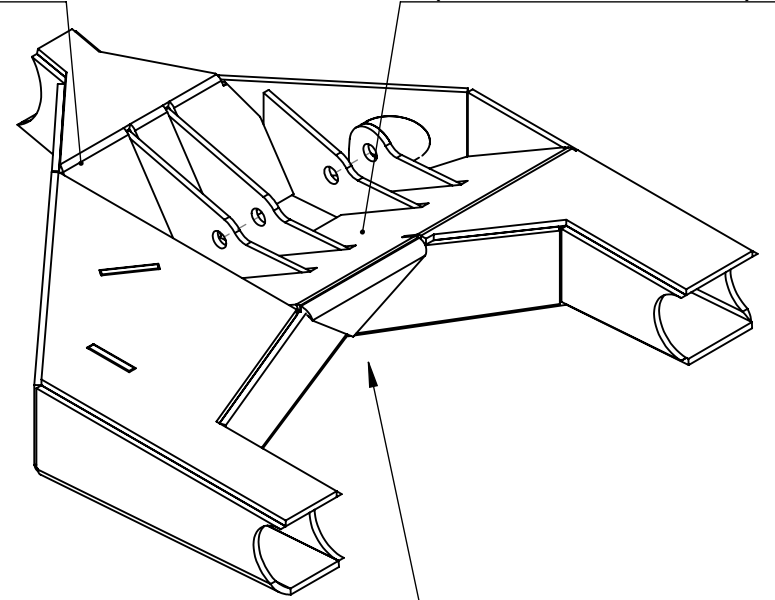
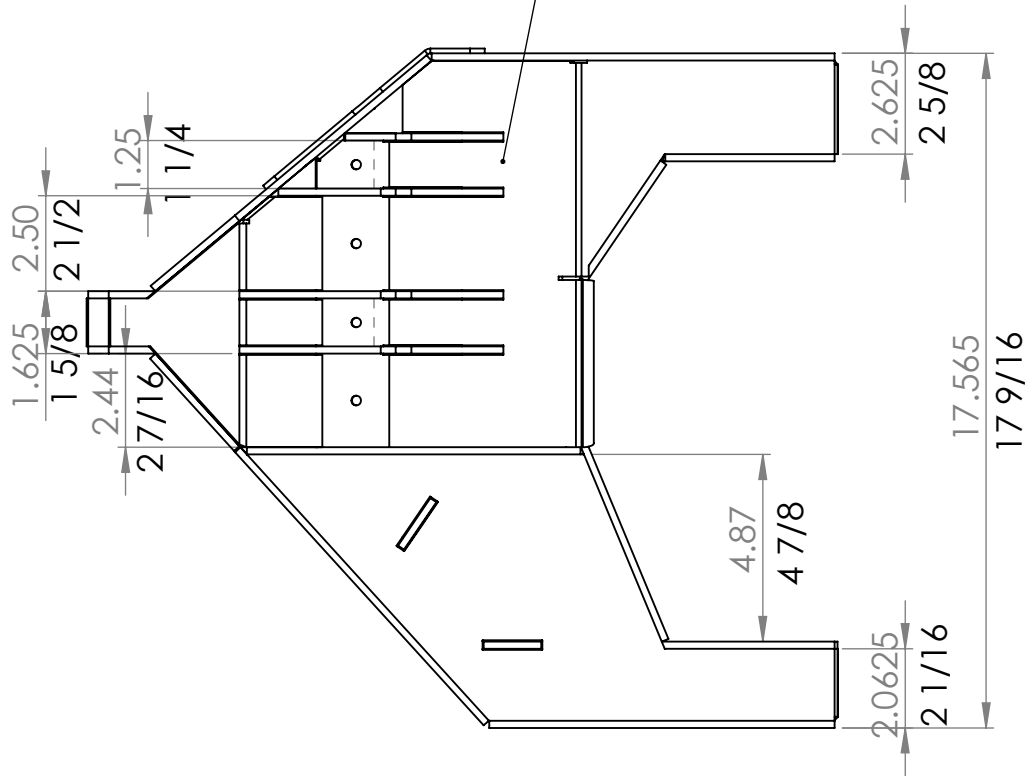

TEST FIT TOP  
PLATES BEFORE  
WELDING BEGINS

PROPRIETARY AND CONFIDENTIAL  
THE INFORMATION CONTAINED IN THIS  
DRAWING IS THE SOLE PROPERTY OF  
<INSERT COMPANY NAME HERE>. ANY  
REPRODUCTION IN PART OR AS A WHOLE  
WITHOUT THE WRITTEN PERMISSION OF  
<INSERT COMPANY NAME HERE> IS  
PROHIBITED.

		UNLESS OTHERWISE SPECIFIED:	NAME	DATE	
		DIMENSIONS ARE IN INCHES TOLERANCES: FRACTIONAL ± ANGULAR: MACH ± BEND ± TWO PLACE DECIMAL ± THREE PLACE DECIMAL ±	DRAWN		TITLE: LCA TAB SPACING
			CHECKED		
			ENG APPR.		
			MFG APPR.		
		INTERPRET GEOMETRIC TOLERANCING PER:	Q.A.		
		MATERIAL	COMMENTS:		
		FINISH			SIZE DWG. NO. REV
NEXT ASSY	USED ON				A PASSENGER LCA TAB SPACING
APPLICATION		DO NOT SCALE DRAWING			SCALE: 1:5 WEIGHT: SHEET 1 OF 1

5

4

3

2

1